

General Description

Threaded Cartridge Style Counterbalance Valve. Pilot assisted, designed for motion control applications. For additional information see Technical Tips on pages LM2-LM5.

Features

- Poppet construction for minimal leakage
- Incorporates direct acting relief valve for overload protection
- Includes reverse check valve within body, saving space and minimizing installation cost
- Two pilot ratios available, 3:1 for cylinders and 8:1 for motor control
- Hardened working parts for maximum durability
- All external parts zinc plated

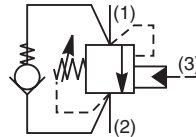
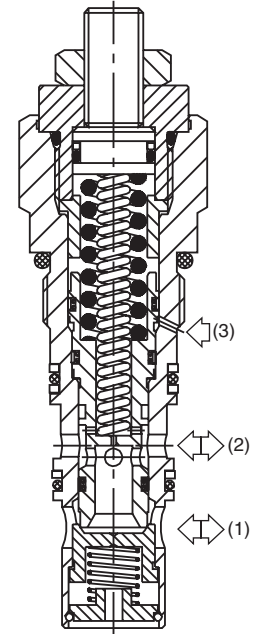

Specifications

Rated Flow	60 LPM (15.9 GPM)
Pressure	50 - 350 Bar (725 - 5000 PSI)
Sensitivity: Pressure / Turn	99 Bar (1435 PSI)
Pilot Ratio	E2A040 - 8 : 1 E2B040 - 3 : 1
Cartridge Material	All parts steel. All operating parts hardened steel.
Operating Temp. Range/Seals	-34°C to +121°C (Nitrile) (-30°F to +250°F) -26°C to +204°C (Fluorocarbon) (-15°F to +400°F)
Fluid Compatibility/ Viscosity	Mineral-based or synthetic with lubricating properties at viscosities of 45 to 2000 SSU (6 to 420 cSt)
Filtration	ISO-4406 18/16/13, SAE Class 4
Approx. Weight	0.27 kg (0.6 lbs.)
Cavity	68-1 (See BC Section for more details)

Performance Curves

Relief & Pilot Performance 1 to 2

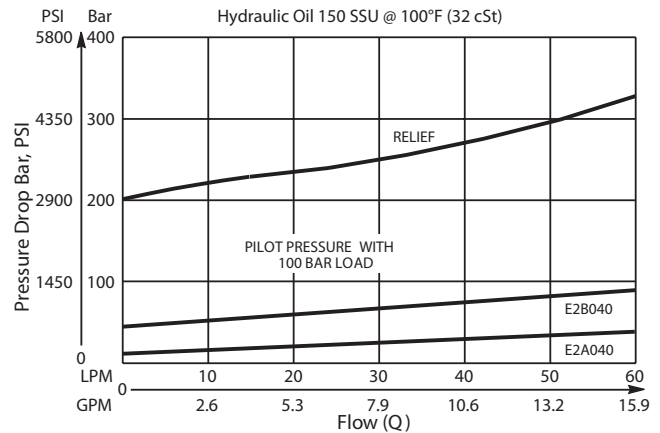

Pressure Drop vs Flow

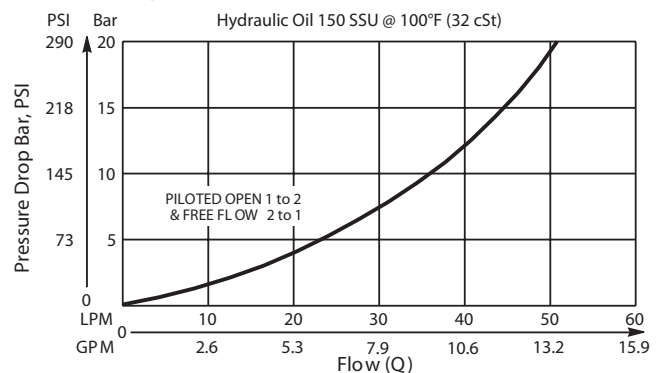

- CV**
Check Valves
- SH**
Shuttle Valves
- LM**
Load/Motor Controls
- FC**
Flow Controls
- PC**
Pressure Controls
- LE**
Logic Elements
- DC**
Directional Controls
- SV**
Solenoid Valves
- PV**
Proportional Valves
- CE**
Coils & Electronics
- BC**
Bodies & Cavities
- TD**
Technical Data

Dimensions Millimeters (Inches)

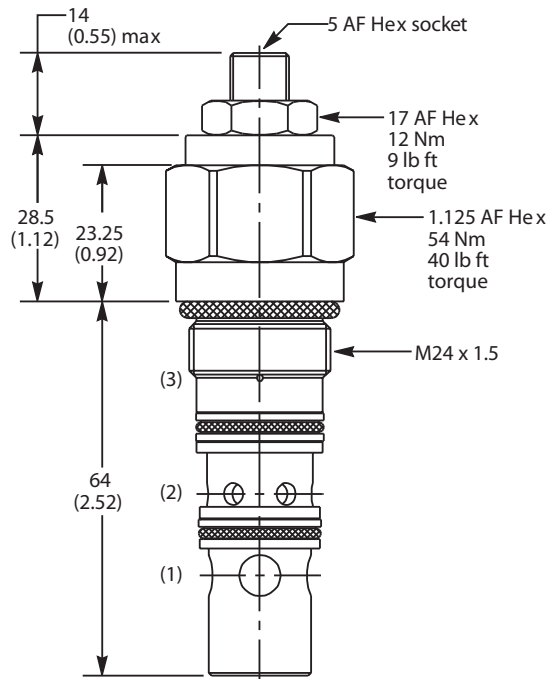

Ordering Information

E2		040	Z	N	MK3
Load Control Valve	Pilot Ratio		Adjustment Style	Seals	

Highlighted represents preferred options that offer the shortest lead times. Other options may be available, but at extended lead times.

Code	Pilot Ratio
A	8 : 1
B	3 : 1

Code	Adjustment Style
Z	Screw Adjust (Standard)

Code	Seals
N	Nitrile

Order Bodies Separately
 See section BC

LB10	253	S
Line Body	Porting	Body Material

Code	Porting
253	1/2" SAE (main) 1/4" SAE (aux)

Code	Body Material
S	Steel //(5000PSI)

Kit	Part Number
Tamper Resistant Cap	TC1130
Nitrile Seal	SK30059N-1
Fluorocarbon Seal	SK30059V-1

*Standard valve is set to crack at 215 Bar (3120 PSI). Valve to be set to 1.3 times maximum load induced pressure.

CV
Check Valves
SH
Shuttle Valves
LM
Load/Motor Controls
FC
Flow Controls
PC
Pressure Controls
LE
Logic Elements
DC
Directional Controls
SV
Solenoid Valves
PV
Proportional Valves
CE
Coils & Electronics
BC
Bodies & Cavities
TD
Technical Data